

## A Web-enabled digital power meter

**Phalguna Devalaraju**

University at Buffalo  
Amherst, NY 14260, USA  
[pd6@buffalo.edu](mailto:pd6@buffalo.edu)

**Darold Wobschall**

Eensors, Inc.  
Amherst, NY 14226, USA  
[designer@eesensors.com](mailto:designer@eesensors.com)

### ABSTRACT

*A digital power meter with a direct Internet access was developed based on the previously reported websensor concept. Line power is measured with a Cirrus Logic CS5460A single-phase bi-directional power-energy IC which has two analog inputs (150 mV RMS full scale), dual A/D converters and a multiplier used to calculate true power and RMS voltage/current. Line voltage and current are scaled to the IC input with a voltage divider (1000:1) and a current shunt (5 mΩ), respectively. Binary data from the energy IC is transmitted to a microprocessor (PICmicro) which converts it into human readable (ASCII) form and sends it through the Ebus to a communication module, which reformats it into TCP/IP protocol format and transmits it over the Ethernet (Fig. 1). Up to 9 digital power meters may be connected on the optically isolated Ebus. The circuit, on 3 circuit boards, fits in a case which plugs into a standard wall socket (Fig. 2).*

### KEYWORDS

Websensor, powermeter, smart sensor, Internet, Ethernet

### 1.0 INTRODUCTION

For successful energy management and control, ubiquitous power meter data is very important. A digital power meter with an IP address of its own facilitates electrical measurements from anywhere on the internet. Such a power meter which is inexpensive and built from off-the-shelf hardware is an ideal solution for remote power monitoring.

World Wide Web (WWW) is the most widely used tool for information exchange throughout the world. In just a few years, what was originally confined to the government, industry, and academia has become common in offices and homes with literally millions of web addresses vying for customers and viewers. One area of the web technology that is attracting attention from the industry/customers is the useful application of this technology to the remote acquisition of data from sensors. Process monitoring and control over the internet using web-enabled sensors is one of the today's hot technologies. But this is largely hindered due to several factors including the cost of providing a server computer acting as the interface for various suites of sensors and the lack of security that accompanies the open format of the WWW. The **websensor** technology advocated in this paper tries to alleviate the above factors.

The websensor itself is a small website that has been designed with relatively small memory and capability in order to minimize cost and data transfer time. Its main function is to send an email, which includes the sensor data, upon the request of a central website. The central website is similar to a standard website except that it is programmed to request data at periodic intervals, and update its database on all sensors for which it is responsible. Real-time data is sent in the form of an e-mail to the user when requested, and logged data waveforms/values can be accessed by the user through the central website. Security of data is ensured by a user-specific sensor code, user name and password.

The digital power meter presented in this paper measures single-phase electrical parameters: AC voltage (rms), AC current (rms), true power (watts). It then computes power factor and energy (watt-hrs). All the measurements are made with an accuracy of 0.2% that is suitable for power metering applications. The nominal input range of the power meter is 120V<sub>rms</sub> on the voltage channel and 20A<sub>rms</sub> on the current channel. Any sudden changes in the measured data like drastic voltage drops below a pre-set limit or over limit currents are immediately conveyed to the user through alerting e-mails.

This power meter is a part of a range of websensors being currently developed. Multiple websensors can be networked locally to form a monitoring system such as a Building Management System. The local bus used for this network is called the Ebus [2] which is based on the SPI serial bus. This network of sensors can transmit the collected data in TCP/IP format over the Ethernet through an Internet-compatible communications module. The network side of the communication module handles the TCP/IP protocol and this is able to receive commands and send HTTP data over the Internet.

### BLOCK DIAGRAM OF A NETWORKED SENSOR

A block diagram of a typical [1] networked sensor (Websensor) is shown in the Figure 1.

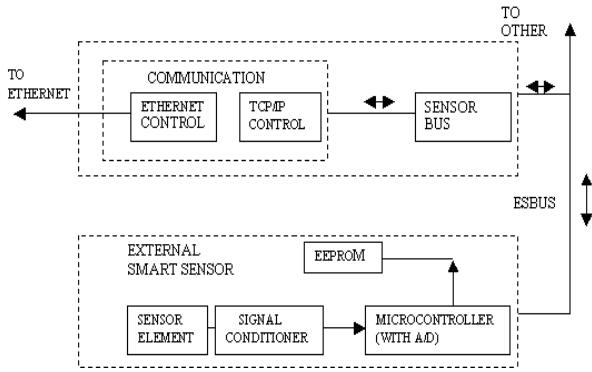

Fig. 1 Block Diagram of a Networked Sensor

## 2.0 SYSTEM DESCRIPTION

The digital power meter can be viewed as two main modules: ES02 and EM02, the slave and the master units respectively. The ES02 module makes the measurements, converts them into the Ebus data format and transmits this data over the Ebus to the EM02 module. Upto 9 ES02 units can be connected to an EM02 unit over the Ebus with each slave unit having a specific channel number.

### 2.1 ES02 Overview:

This module plugs into the power line socket and contains the power meter IC [4]. It measures the required electrical parameters and converts them into the Ebus protocol format. This data which is in the ASCII format is updated and stored at regular intervals (typically 1 sec). The communication board of this module interfaces with the communication board of the EM02 module through a 3 wire SPI interface and two communication control signals. The EM02 module polls this module for updated measurements at regular intervals. The 8-byte command received from the master module is decoded and the sensor data requested is sent in four 8-byte words including a header. The power supply required for this module is derived from the line and is of the order of 7mA. The complete integrated ES02 module can be seen in Figure 2.



Fig. 2 Integrated ES02 module with the plug-in case

### 2.2 EM02 Overview:

The EM02 unit connects directly to Ethernet with its own IP address, configured using an ES00r module at the time of installation. The communication section of the EM02 is based on the Uvicom SX stack and the EX01 board shown in Figure 3 is a modified version of the Uvicom evaluation board.



Fig. 3 EM02 module. Communication (TCP/IP & Ethernet) is on top

The function of the communication board is to receive and send HTTP data in blocks of predetermined length, suitable for sensor data communication. Network data is transmitted through a standard Ethernet interface (8 pin modular connector, RJ45). The HTTP command in and HTTP data out is transferred to the master board (EM02) through the Ebus (3-wire SPI) operating at a clock frequency of 10 KHz. Data is always transferred in 8-byte blocks, and with the mode used for the EM02, a total of 32 bytes are transferred (after stripping off the standard Internet/Ethernet headers). Two handshaking lines control data exchange on the SPI bus between the ES02 and EM02 modules. Also there are timing restrictions but the data transfer is handled by a subroutine provided with the master microprocessor (PIC) software.

The block diagram of network enabled digital power meter is shown in Figure 4.

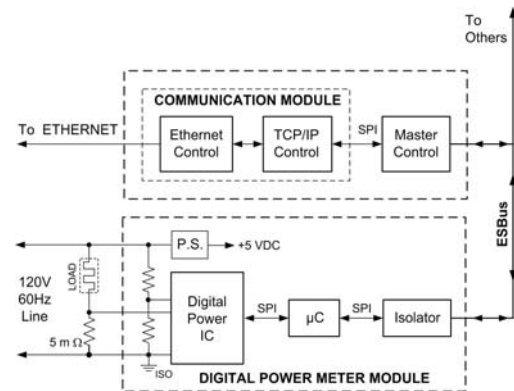

Fig. 4 Block Diagram of the Digital Power Meter with Ebus and Internet Interface

### 3.0 ESBUS INTERFACE

#### 3.1 CIRCUIT

The Eibus, based on the SPI serial bus, is shown in Figure 5.

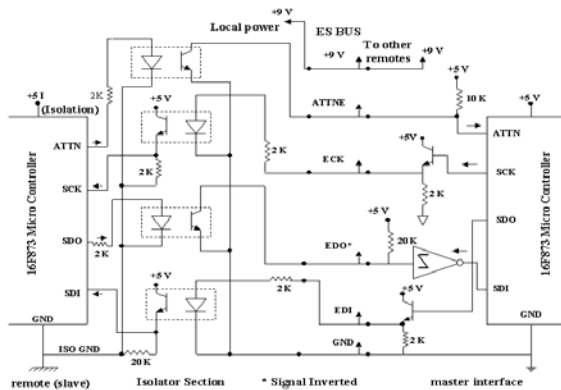

Fig. 5 Eibus Circuit Diagram

The microprocessor connected to the network communications unit is the SPI master and thus supplies the clock signal (10 KHz). A byte of data is exchanged between the master and slave for each 8-clock cycle. Optical isolators provide ground isolation for safety and noise reduction. Data (commands) are transmitted from the master along the EDI line (the “I” refers to the input data for the remote sensor). At the sensor end, the signal is connected to the data input (SDI) of the SPI serial bus on the microcontroller.

Data (sensor information) from the slave is transmitted on the EDO line (the “O” refers to the output of the remote sensor). At the sensor end the data line is connected to the signal input (SDO) of the SPI serial bus on the microcontroller. The isolator output (phototransistor) pulls down the signal line (pull up resistor to +5 volts on the master end) so the EDO line is inverted (Fig. 5). Multiple remote sensors may be connected to the EDO line in an open collector multiplexed configuration. This arrangement allows the sensors to be networked if the EDO line is zero, or off, when data is not being transmitted by the unselected sensor or slave unit. An optional attention line (ATTNE) to signal to the master that data is available from the sensor is available.

#### 3.2 BUS DATA TIMING AND WAVEFORMS

The Eibus timing diagram is shown in Figure 6

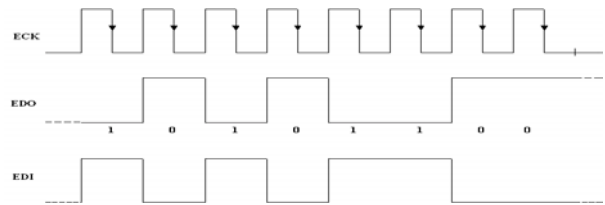

Fig. 6 Eibus Waveform

### 4.0 COMMAND AND DATA FORMATS

The command from the user specifies the particular sensor, the data format of the sensor data, the command to be executed and any data required (Ex: calibration). This is an 8-byte command word and broadcast to all sensor nodes by the master. The node with the channel number matching that in the command word responds with the data in the format shown above. The command byte can be used to calibrate the power meter or to get different sets of measured data. The slave unit responds with a 0 when receiving the first 8-byte command clocked by the master. The master then waits for 10mSec before clocking in the sensor data. The 8-byte header and 32-byte data are clocked in by the master which sends out zeros while doing so. For sending an alert, the sensor unit uses the ATTNE line of the Eibus which in turn makes the master unit to send out an e-mail to the user.

<i>Command from the user's browser</i>
<p><b>Ecfybbbb</b>  e – Header character  c – Channel/Sensor # (1-9)  f – Data format code  y – Command byte  bbbb – Command data if any  <b>Ex: e1120000</b></p> <p><i>Sent by the user through the Esensors website</i>  <a href="http://www.eesensors.com/e4100000/">www.eesensors.com/e4100000/</a></p>
<i>Data from the power meter</i>
<p><b>Header: Eiiiiicfw</b>  E – Header character  iiii – Sensor ID  c – Channel/Sensor # (1-9)  f – Data format code  w – Status/Command byte  <b>Ex: ES02a110</b>  <b>Data: ssddd.dd</b>  <b>Ex: Va120.00; Pf0.9995; Pa1500.0</b></p> <p><i>Sent by the power meter through Ethernet as e-mail</i></p>

## 5.0 RESULTS

The data read command from the Internet, with HTTP format, is: **e1120000**. The data returned by the digital power meter is: **ES02a110Va120.00Pa1200.0Q0.9995** where Va is the RMS voltage, Pa is the true power (watts), and Q is the power factor. Examples of data are given in Table 1. Typical accuracy (power and voltage) is 0.2%. Line current (rms) is calculated at the PC end from the Va, Pa and Q.

Inputs				Measured Values		
Line Volts V RMS	Line Amp A RMS	V-Input mV RMS	I-Input mV RMS	Power Watts	Volts V RMS	Quality Factor Q
20.00	0	20.00	0	0.0	20.00	0.0
120.0	5.0	120.0	25.0	600.9	120.0	0.999
120.0	15.0	120.0	75.0	1801.5	120.0	0.999
171.0	0	171.0	0.0	0.0	169.9	0.0

Table. 1 Measured Data

The measurement data from the digital power meter when compared with a reference multimeter is found to be in the 0.2% accuracy range. The reference used was: *Enetics* LMS-5750 PowerScope.

One motivation for employing smart sensor technology is system cost reduction. The cost reduction estimated for the websensor compared to the conventional sensors is summarized in the Figure 7.

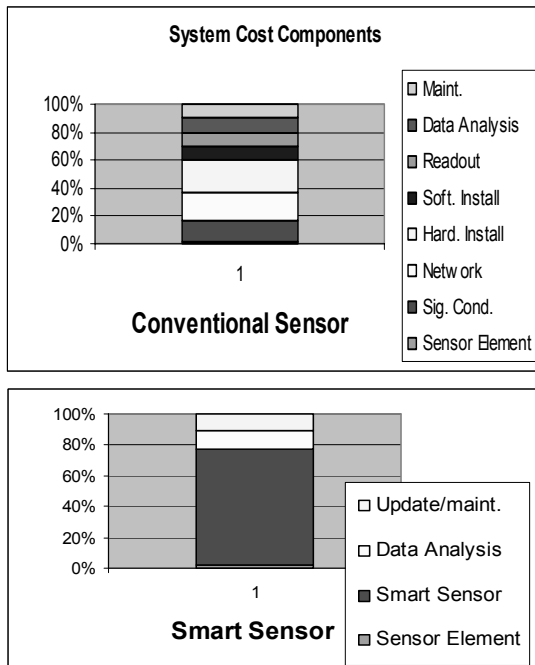

Figure 7 Smart Sensor Cost Comparison

## 6.0 CONCLUSIONS

A simple low cost digital power meter with Internet capability has been developed. Multiple power meters can be networked into a simple digital network designed to interconnect smart sensors on a local bus. This network enabled power sensor is very useful for power monitoring in small office, small industry and home environments. A network of these power meters combined with other sensors could be effective in Building Management Systems. The concept presented here is being extended to 3-phase power meters useful in high power measurements (industry oriented). Short-range wireless networking capability is also being incorporated into the present model to facilitate use in congested environments.

## REFERENCES

- [1] R.Frank "Understanding Smart Sensors", 2<sup>nd</sup> edition, Artech House (2000)
- [2] D.Wobchall, "Websensor Design – Smart sensors with an Internet Address" Proceeding Sensors Expo (Philadelphia, Oct. 2001)
- [3] IEEE-P1451 "A Smart Transducer Interface Standard for Sensors and Actuators"  
<<http://www.ic.ornl.gov/p1451/p1451.html>>
- [4] Cirrus Logic CS5460A Single-Phase, Bidirectional Power/Energy IC Specifications <[www.cirrus.com/](http://www.cirrus.com/)>