

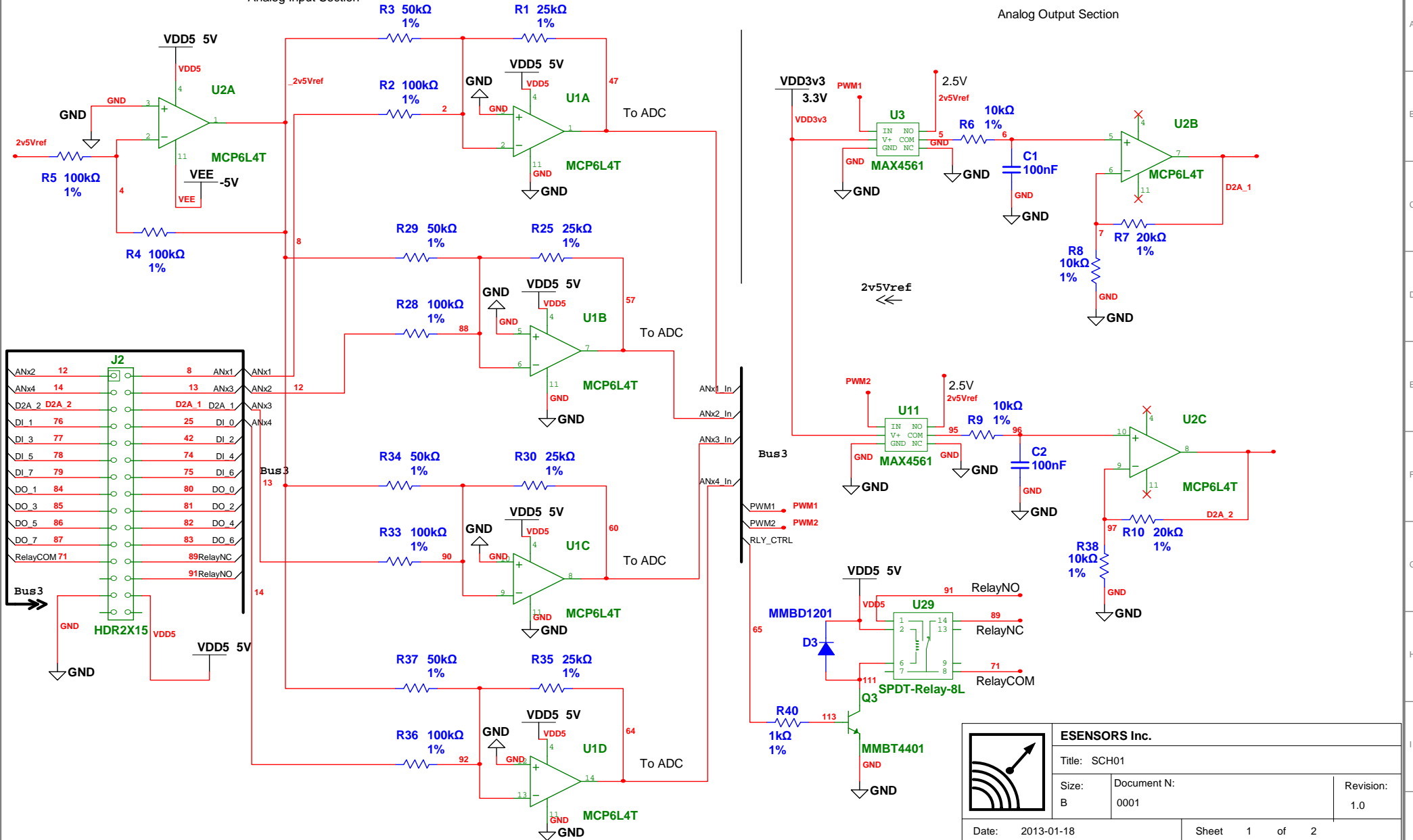



Analog Input Section

Analog Output Section

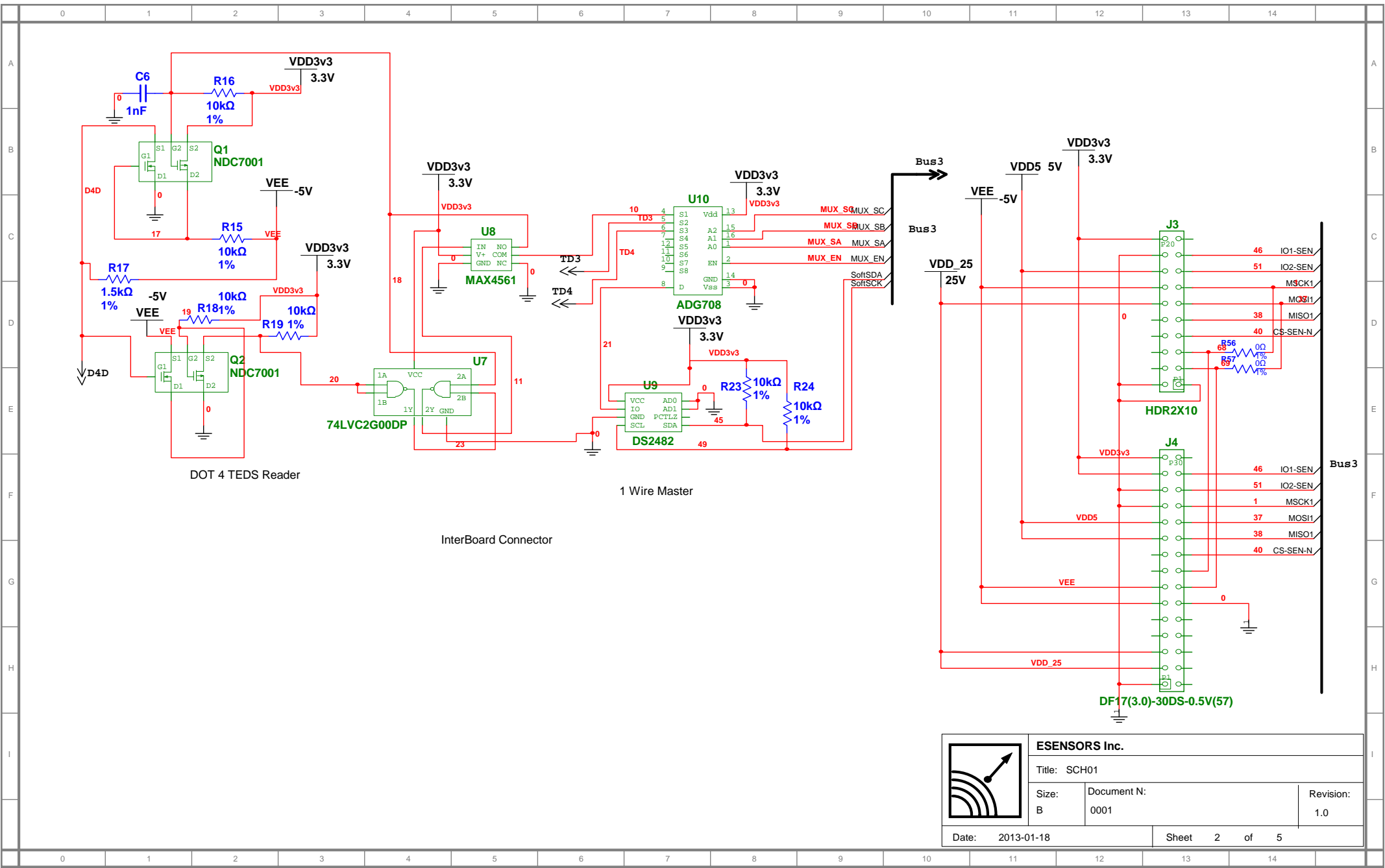

			ESENSORS Inc.		
			Title: SCH01		
Size:	Document N:		Revision:		
B	0001		1.0		
Date:	2013-01-18		Sheet 1 of 2		



 ESENSORS Inc.		
Title: SCH01		
Size: B	Document N: 0001	Revision: 1.0
Date: 2013-01-18	Sheet 2 of 5	

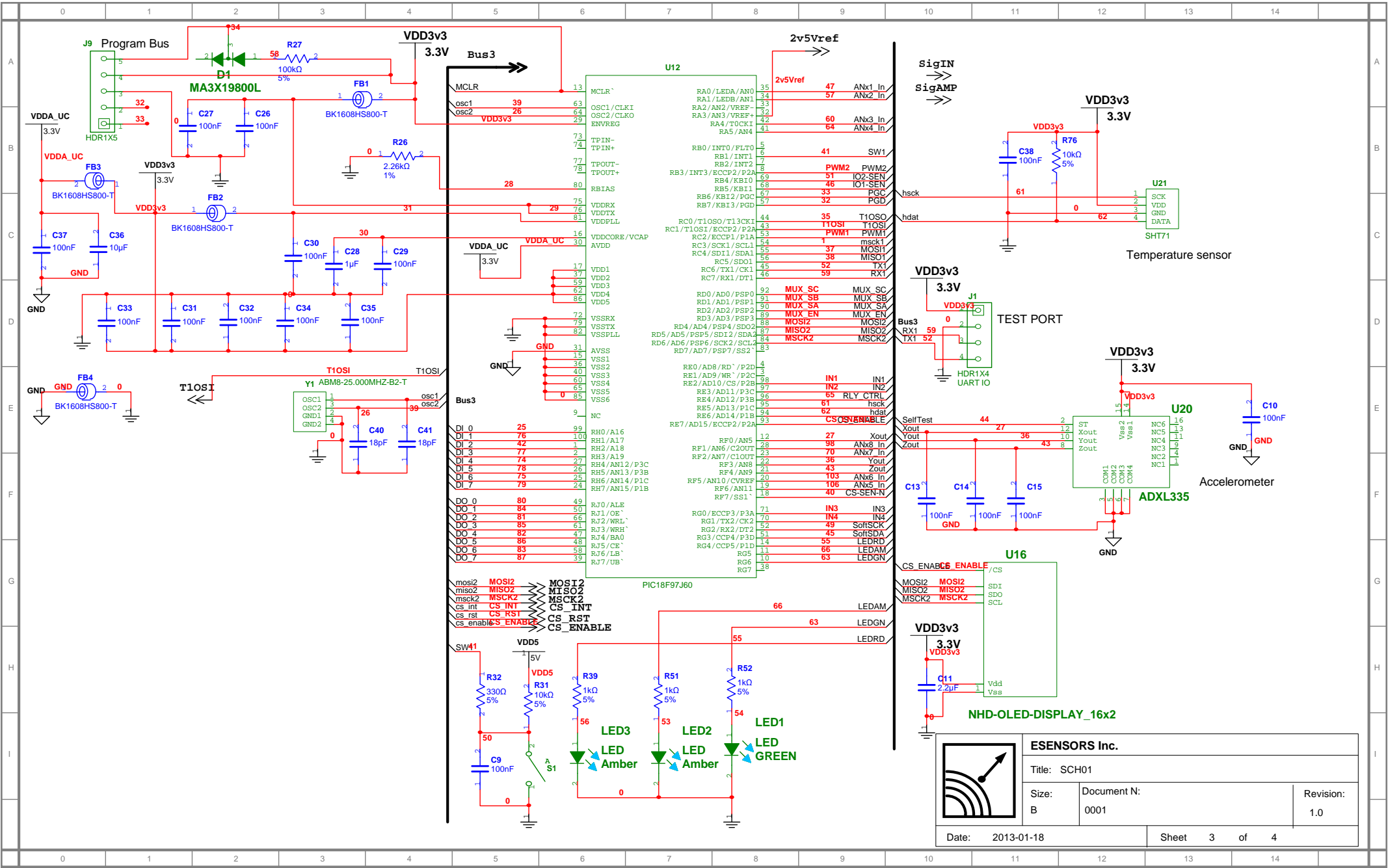

			ESENSORS Inc.		
			Title: SCH01		
Size:	Document N:	Revision:			
B	0001	1.0			
Date:	2013-01-18		Sheet	3	of 4

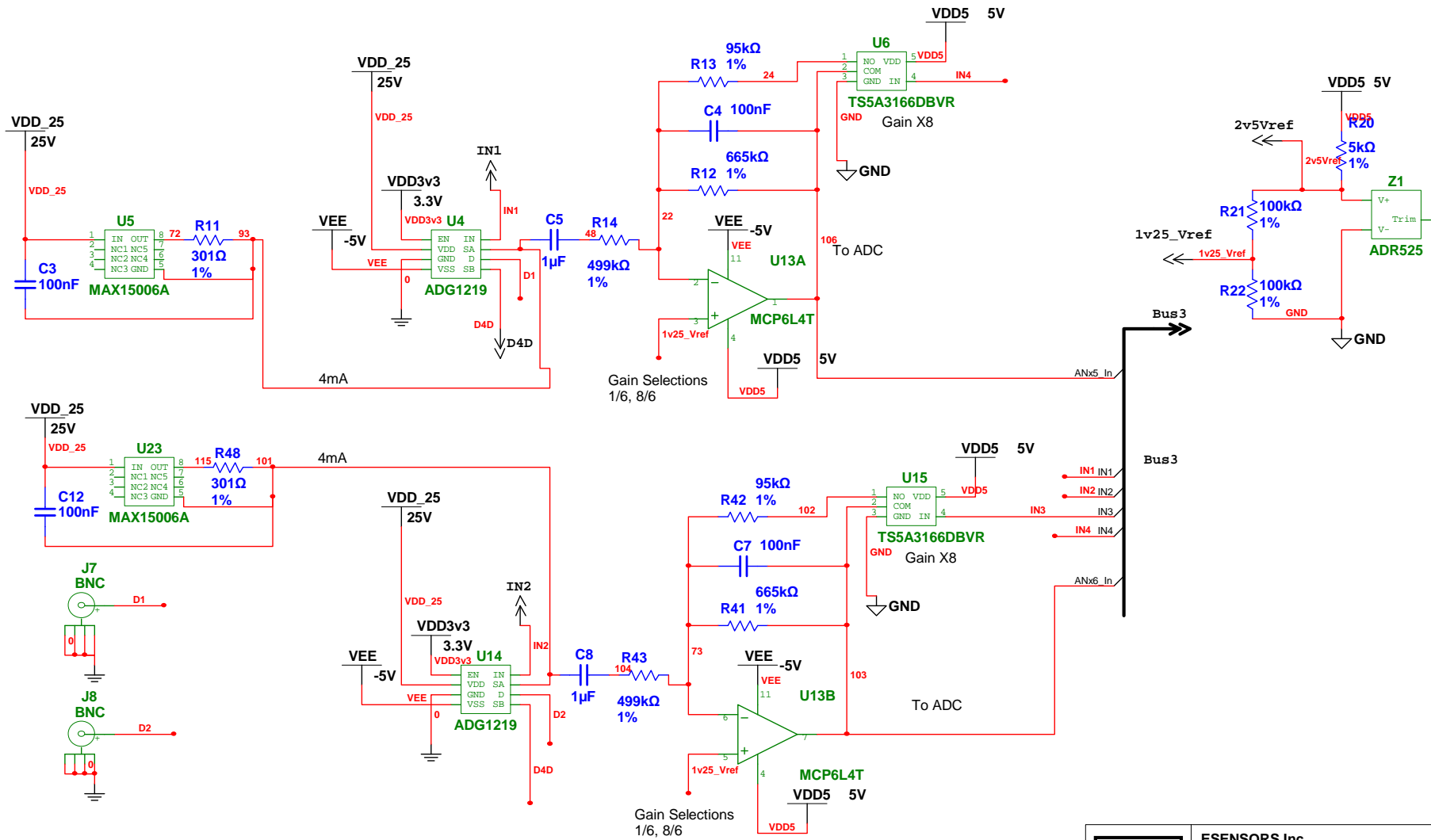

			ESENSORS Inc.		
			Title: SCH01		
Size:	Document N:	Revision:			
B	0001	1.0			
Date:	2013-01-18	Sheet	4	of	5

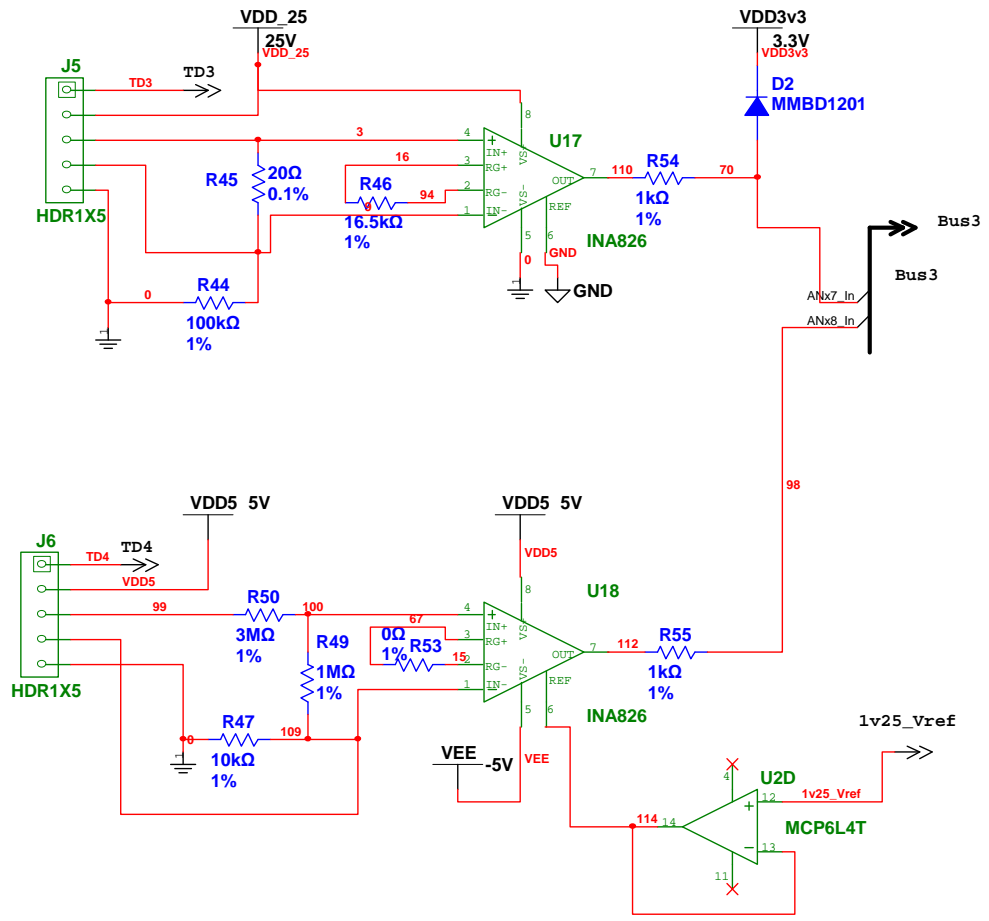

 ESENSORS Inc.			
			Title: SCH01
Size: B	Document N: 0001	Revision: 1.0	
Date: 2013-01-18		Sheet 5 of 5	